

The AC plasma torch operating on a mixture of argon and hydrogen sulfide

© A.V. Surov, S.D. Popov, D.I. Subbotin, E.O. Serba, G.V. Nakonechny, A.V. Nikonov,
K.I. Babich, Y.S. Denisov

Institute for Electrophysics and Electric Power, Russian Academy of Sciences, St. Petersburg, Russia
E-mail: yra-denisov2001@yandex.ru

Received March 27, 2025

Revised April 20, 2025

Accepted April 21, 2025

The article discusses a new model of the AC plasma torch, which can be used to process hydrogen sulfide into hydrogen gas and molecular sulfur. The dependences of the arc voltage drop and the power on the hydrogen sulfide flow rate has been established.

Keywords: High voltage AC plasma torch, hydrogen sulfide, arc voltage drop, hydrogen.

DOI: 10.61011/TPL.2025.07.61438.20325

As the requirements for environmental performance of motor fuels become more stringent, the concentration of sulfur in them decreases. Since the main method for removal of sulfur from hydrocarbon fractions is hydrotreating, sulfur compounds of petroleum fractions are converted into hydrogen sulfide. Its amount also increases with an increase in the sulfur content of oil. The main method of hydrogen sulfide processing is the Claus process in which hydrogen sulfide is converted into molecular sulfur and water [1]. Sulfuric acid, rubber products, and individual sulfur-containing compounds are then produced from molecular sulfur. However, hydrogen contained in hydrogen sulfide cannot be retrieved in molecular form in the Claus process, although numerous calculations show that hydrogen and molecular sulfur are formed in the course of high-temperature thermal decomposition of hydrogen sulfide (at more than 2000 K) [2]. Such temperature levels may be achieved using plasma sources. The fundamental possibility of pyrolysis of hydrogen sulfide with various types of plasma has been established reliably in the second half of the 20th century [3].

Low-capacity experimental setups decomposing hydrogen sulfide under the influence of barrier [4], corona [5], and glow discharges [6] reached relatively high degrees of hydrogen sulfide conversion, but the specific energy consumption for hydrogen production was extremely high. Another problem with such devices was their low productivity, whereas the mass of hydrogen sulfide generated in the petrochemical industry is estimated at millions of tons per year.

In the 1980s, the processing of hydrogen sulfide with microwave plasma torches has been studied by a research group led by Academician V. Rusanov, and the advantages of high-power plasma sources in this field have been demonstrated [7]. However, the thermal efficiency and service life of such plasma torches were limited. Electric arc plasma torches [8] and a large number of microwave plasma torch models [9–11] are currently being examined in relation

to hydrogen sulfide processing. It becomes increasingly important to enhance the plasma torch unit capacity, since this is what defines whether plasma pyrolysis is applicable in industrial processing of hydrogen sulfide. New designs with a power exceeding 300 kW [12,13] are being developed. In the present study, we report new data for a high-voltage AC plasma torch running on a mixture of argon and hydrogen sulfide.

The results were obtained using an experimental setup that included a three-phase AC plasma torch, a power supply system with an open-circuit voltage of 10 kV, a system for supplying and measuring the flow rate of plasma-forming gas, a cooling system with a system for thermal efficiency measurement, and a system for measuring and recording the parameters of electric arcs. The plasma torch diagram is shown in Fig. 1.

The plasma torch body houses three flow discharge channels with copper rod electrodes mounted with insulators. Gases are supplied tangentially into different sections of the discharge channels. Tangential gas injection ensures axial stabilization of electric arcs. One part of argon ($3 \cdot 10^{-3}$ kg/s) is fed into the discharge channels at the electrodes to protect them from the aggressive action of hydrogen sulfide. The other part ($3 \cdot 10^{-3}$ kg/s) is injected further downstream in the main arcing zone. The plasma torch operation is initiated with pure argon, and hydrogen sulfide is then mixed into the argon flow in the arcing zone. Arcs are ignited by means of unassisted breakdown of the minimum gaps between the electrodes and the walls of discharge channels due to a high open-circuit voltage of the power source. Electric arcs are extended along the axes of the discharge channels under the influence of flowing gas and close together at the exit. When the current strength passes through zero, arcing resumes in the axial regions of the discharge channels where conductivity is preserved.

The power supply system includes switching equipment, a system for measuring and recording electrical parameters, current-limiting inductors in each phase, a step-up

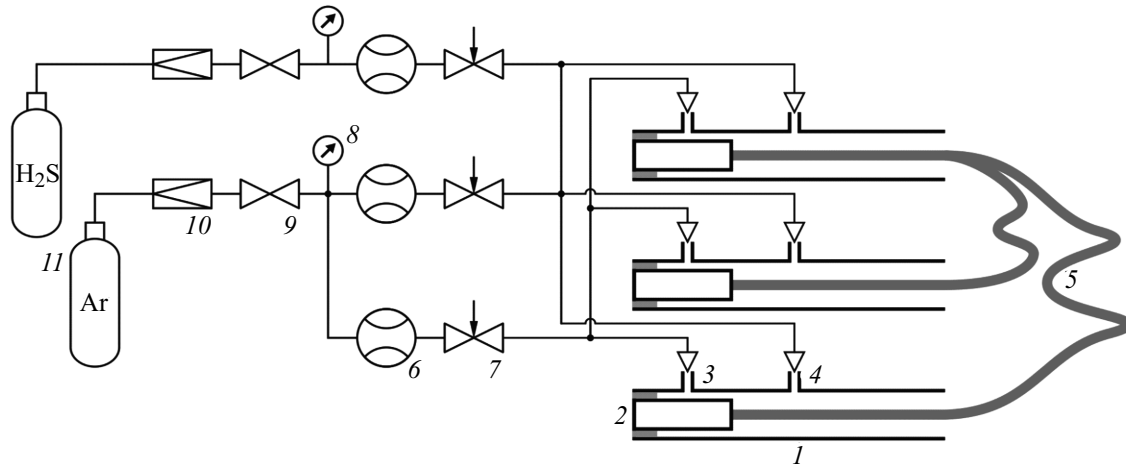

Figure 1. Plasma torch diagram. 1 — Discharge channel, 2 — electrode, 3 and 4 — gas inlets, 5 — arc, 6 and 7 — gas flow regulator, 8 — pressure gauge, 9 — valve, 10 — reducer, and 11 — cylinder.

transformer, and a reactive power compensation system. Inductors limit the current, dampen the electric arc current pulsations, and ensure re-ignition in the event of arc extinction.

The gas supply system features gas ramps with cylinders and shut-off and control devices (valves, gas cylinder reducers). Gases are supplied through Bronkhorst mass flow controllers with an upper measurement limit of $7 \cdot 10^{-3}$ kg/s for argon and $0.63 \cdot 10^{-3}$ kg/s for hydrogen sulfide; flow measurement errors include 0.5% of the measured value plus 0.1% of the upper measurement limit.

The plasma torch cooling system provides the required flow of cooling water at an excess pressure of 0.6 MPa. The thermal efficiency of the plasma torch is determined by measuring heat losses based on the difference in temperature of cooling water at the inlet and the outlet of the plasma torch cooling circuit and its flow rate. The heat loss measurement device and the measurement procedure were detailed in [14].

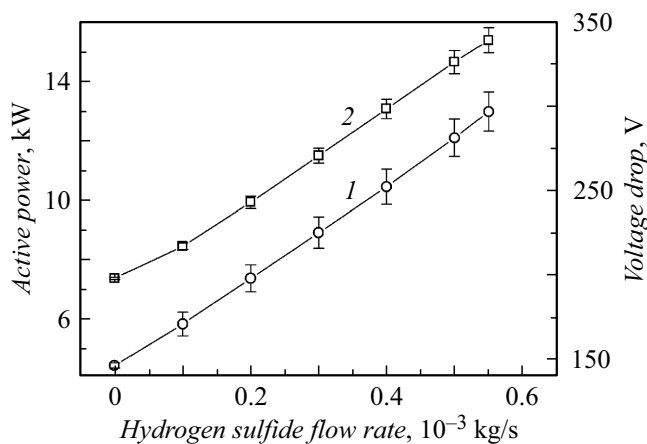

Figure 2. Dependences of voltage drop (1) and active power (2) of the plasma torch on the mass flow rate of hydrogen sulfide; the argon flow rate in the electrode zone is $3 \cdot 10^{-3}$ kg/s, the argon flow rate in the arcing zone is $3 \cdot 10^{-3}$ kg/s, and the average effective current value is 31.8 A.

The power supply system includes a system for measuring and recording the electrical parameters of the plasma torch, which was constructed on the basis of an Advantech IPC-510 industrial computer with 12-bit analog-to-digital converters (500 kHz) produced by National Instruments with a sampling rate of 32 kHz in each channel for processing signals from current and voltage sensors. The software developed in LabVIEW allows one to calculate the effective current and voltage values and the plasma torch power based on their instantaneous values and record oscilloscope patterns of current and voltage to a computer storage device. LA 55-P (LEM S.A.) current sensors with a measurement range from -70 to 70 A, an accuracy of $\pm 0.65\%$, a nonlinearity of $< 0.15\%$, a delay time of $< 1 \mu\text{s}$ at 90% of the maximum value within the measurement range, and a frequency range of 0–200 kHz are used for current measurement. I50 voltage transformers (nominal transformation ratio, 10 000/100 V; accuracy class, 0.2) and LV 100/SP51 (LEM S.A.) voltage sensors with a configurable measurement range from ± 100 to ± 4500 V, an accuracy of $\pm 0.7\%$, a nonlinearity of $< 0.1\%$, a delay time of 20–100 μs at 90% of the maximum value within the measurement range, a frequency range of 3 kHz are used for voltage measurement.

Figure 2 shows the experimental dependences of the arc voltage drop and the active power of the plasma torch on the mass flow rate of hydrogen sulfide at a fixed argon flow rate.

An increase in flow rate of plasma-forming gas normally leads to an increase in arc voltage drop and active power. This is attributable to an arc temperature reduction and a corresponding reduction of electrical conductivity. The decrease in arc temperature is caused by the intensification of gas-arc heat exchange and dissociation (in the case of polyatomic gases). It should be noted that an increase in argon flow rate in the arcing zone to $3.5 \cdot 10^{-3}$ kg/s has virtually no effect on the electrical parameters if hydrogen sulfide is not supplied. The arc voltage drop and the

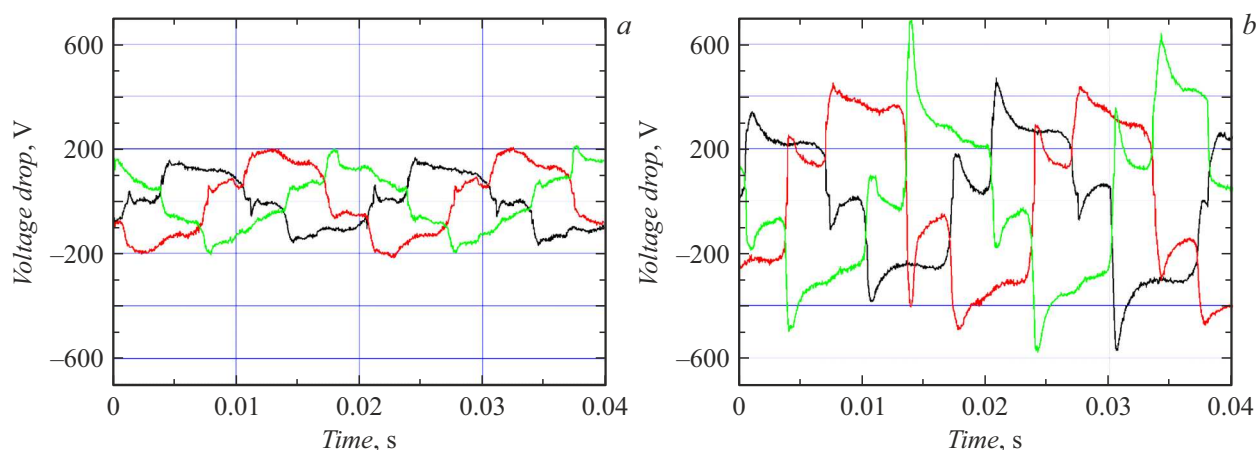

Figure 3. Oscilloscope records of voltage drop without hydrogen sulfide (a) and with a hydrogen sulfide flow rate of $0.4 \cdot 10^{-3}$ kg/s (b); the argon flow rate in the electrode zone is $3 \cdot 10^{-3}$ kg/s, the argon flow rate in the arcing zone is $3 \cdot 10^{-3}$ kg/s, and the average effective current value is 31.8 A. Each curve corresponds to the voltage drop between the phases of the three-phase power supply system.

active power increase approximately by 2%. This is attributable to the relatively low heat capacity and thermal conductivity of argon. It can be seen from Fig. 2 that the arc voltage drop increases significantly as a result of a relatively small increase in hydrogen sulfide flow rate. Specifically, with a fixed total argon flow rate of $6 \cdot 10^{-3}$ kg/s and the hydrogen sulfide flow rate increasing from 0 to $0.55 \cdot 10^{-3}$ kg/s, the voltage drop grows from 146 to 297 V. The active power increases from 7.4 to 15.4 kW in the process. The dependences are near-linear in nature. When hydrogen sulfide is supplied, hydrogen and elemental sulfur are produced under the energy influence of electric arcs. A part of the electric arc energy is consumed in this endothermic process. Since hydrogen has high values of heat capacity and thermal conductivity, the heat exchange with the arc is intensified and the voltage drop and power increase significantly. This may also be traced in the oscilloscope records of instantaneous voltage drop values. Figure 3 makes it clear that the injection of hydrogen sulfide alters the shape of oscilloscope records; both the amplitudes of arc ignition peaks and the voltage drop values within arcing intervals increase.

The oscilloscope records of instantaneous current values have a sinusoidal shape and are not shown, since their shape and the current values are virtually independent of the flow rate of argon and hydrogen sulfide (due to the fact that the power supply system is the source of current).

The thermal efficiency was measured for two plasma torch operating modes and was found to be 84% (without hydrogen sulfide) and 90% (at a hydrogen sulfide flow rate of $0.4 \cdot 10^{-3}$ kg/s). The mass-average temperatures were calculated under thermodynamic equilibrium in the indicated conditions: 2280 and 2790 K.

According to [15], electrical discharges at a gas temperature of 2000–4000 K (optimum levels for hydrogen sulfide pyrolysis) create a preferable environment for plasma dissociation of hydrogen sulfide. Thus, the proposed plasma

torch may be used for plasma pyrolysis of hydrogen sulfide to produce molecular sulfur and hydrogen.

Funding

This study was performed under state assignment No. 075-03-2025-020.

Conflict of interest

The authors declare that they have no conflict of interest.

References

- [1] R. Abhijeet, I. Salisu, J. Anoop, *Prog. Energy Comb. Sci.*, **80**, 100848 (2020). DOI: 10.1016/j.pecs.2020.100848
- [2] K. Karan, A.K. Mehrotra, L.A. Behie, *AIChE J.*, **45** (2), 383 (1999). DOI: 10.1002/aic.690450217
- [3] J. Zaman, A. Chakma, *Fuel Process. Technol.*, **41** (2), 159 (1995). DOI: 10.1016/0378-3820(94)00085-8
- [4] Y. Li, F. Gao, Y. Li, C. Shen, C. Liu, *Plasma Chem. Plasma Process.*, **43**, 2079 (2023). DOI: 10.1007/s11090-023-10401-3
- [5] G.-B. Zhao, S. John, J.-J. Zhang, J. C. Hamann, S.S. Muknahalipatna, S. Legowski, J.F. Ackerman, M.D. Argyle, *Chem. Eng. Sci.*, **62** (8), 2216 (2007). DOI: 10.1016/j.ces.2006.12.052
- [6] K. Gutsol, T. Nunnally, A. Rabinovich, A. Fridman, A. Starikovskiy, A. Gutsol, A. Kemoun, *Int. J. Hydr. Energy*, **37** (2), 1335 (2012). DOI: 10.1016/j.ijhydene.2011.10.048
- [7] A. Balebanov, B. Butilin, V. Jivotov, V. Krokvenko, R. Matolich, S. Macheret, G. Novikov, B. Potapkin, V. Rusanov, A. Fridman, V. Yavorski, *Doct. Phys. Chem.*, **283** (1-3), 709 (1985).
- [8] K. Gutsol, R. Robinson, A. Rabinovich, A. Gutsol, A. Fridman, *Int. J. Hydr. Energy*, **42** (1), 68 (2017). DOI: 10.1016/j.ijhydene.2016.12.001
- [9] D. Czyłkowski, B. Hrycak, R. Miotk, M. Dors, M. Jasiński, *Int. J. Hydr. Energy*, **78**, 421 (2024). DOI: 10.1016/j.ijhydene.2024.06.313

- [10] M. Sassi, N. Amira, *Int. J. Hydr. Energy*, **37** (13), 10010 (2012). DOI: 10.1016/j.ijhydene.2012.04.006
- [11] B. Zhang, Z. Song, Y. Pang, J. Zhang, X. Zhao, Y. Mao, J. Sun, W. Wang, *J. Clean. Prod.*, **435**, 140588 (2024). DOI: 10.1016/j.jclepro.2024.140588
- [12] V.L. Satchilembe, E.A. Bushihin, D.V. Ivanov, S.G. Zverev, in *2024 23rd Int. Symp. on electrical apparatus and technologies (SIELA)* (IEEE, 2024), p. 1. DOI: 10.1109/SIELA61056.2024.10637874
- [13] A.V. Surov, S.D. Popov, V.E. Popov, D.I. Subbotin, E.O. Serba, V.A. Spodobin, Gh.V. Nakonechny, A.V. Pavlov, *Fuel*, **203**, 1007 (2017). DOI: 10.1016/j.fuel.2017.02.104
- [14] Ph.G. Rutberg, V.A. Kuznetsov, E.O. Serba, S.D. Popov, A.V. Surov, Gh.V. Nakonechny, A.V. Nikonov, *Appl. Energy*, **108**, 505 (2013). DOI: 10.1016/j.apenergy.2013.03.052
- [15] K. Gutsol, T. Nunnally, A. Rabinovich, A. Fridman, A. Starikovskiy, A. Gutsol, A. Kemoun, *Int. J. Hydr. Energy*, **37**, 1299 (2012). DOI: 10.1016/j.ijhydene.2018.10.035

Translated by D.Safin