

## Investigation of light-current characteristics of InGaN/GaN heterostructure light-emitting diodes in different spectral regions

© V.A. Sergeev<sup>1</sup>, I.V. Frolov<sup>1,2</sup>, O.A. Radaev<sup>1</sup>

<sup>1</sup>Kotelnikov Institute of Radio Engineering and Electronics (Ulyanovsk Branch), Russian Academy of Sciences, Ulyanovsk, Russia

<sup>2</sup>Ulyanovsk State Technical University, Ulyanovsk, Russia

e-mail: ilya-frolov88@mail.ru

Received August 28, 2025

Revised December 11, 2025

Accepted December 13, 2025

The light-current characteristics of ultraviolet, blue, and green LEDs based on InGaN/GaN heterostructures were measured in different regions of the emission spectrum with a spectral resolution of approximately 1.5 nm. Based on the results of measuring and approximating the light-current characteristics with various functions, the threshold current, the current value at which the maximum internal quantum efficiency is reached, and the parameter determining the degree of nonlinearity of the light-current characteristic in the low-current range were determined. It was found that for ultraviolet LEDs, all three parameters depend weakly on the emission spectrum wavelength. For green and blue LEDs, these parameters differ in the short- and long-wavelength regions of the spectrum, and this difference is greater for green LEDs than for blue LEDs. Differences in the parameters of LEDs of different emission colors based on InGaN/GaN heterostructures with quantum wells are explained by differences in concentrations and the nonuniform distribution of indium in the quantum wells of the heterostructure.

**Keywords:** LED heterostructure, emission spectra, light-current characteristics, threshold current, current of maximum quantum efficiency.

DOI: 10.61011/EOS.2026.02.63467.8503-25

### Introduction

Light-current characteristics of a light emitting diode (LED) power on current ( $P-I$ ) is the most important functional characteristic of the LED. To approximate the  $P-I$  characteristic, many authors use the function of  $P(I) = P_0(I/I_0)^a$  type [1–3]. Besides, as it is shown in paper [3], the power exponent  $a$  in the ideal LED is equal to 1, and in the real LED the power exponent value depends on the current: at low currents  $a > 1$ , at high currents  $a < 1$  [3]. Sublinear dependence at high current densities is determined by filling of quantum wells with charge carriers [4]. Superlinear dependence ( $a > 1$ ) of the emission power on current force at low levels of injection is caused by competition between the processes of radiative and nonradiative recombination of the charge carriers. Therefore, the area that is most sensitive to the defects of the light-emitting heterostructure is the area of the  $P-I$  characteristic of the LED in the range of low currents, which is also confirmed by the results of the studies of electrooptic and volt-ampere characteristics, parameters of low-frequency noise etc. [5–10].

In papers [11–13] it is shown that using  $P-I$  characteristics may define the parameters related to the LED heterostructure defects, such as threshold current, internal quantum efficiency (IQE) [11] and the extent of the nonlinearity of the  $P-I$  characteristic in the range of low currents. Besides, the specified approximating function does not reflect all features of the  $P-I$  characteristic of LED in

the range of low currents, since the parameter  $a$  is the current function.

The results of the experimental investigation of  $P-I$  characteristics of LED given in the literature are based on the measurement of the emission power in the full range of the emission spectrum. Measurements of  $P-I$  characteristics not in the full emission spectrum, but in different sections of the emission spectrum make it possible to obtain the additional information on the properties of the light-emitting heterostructure, including on the homogeneity of its composition, which may be used by the manufacturers of LED for the evaluation of their quality, determination of the life resource and reliability as a whole, and also by the developers of wide-band nitride LED heterostructures with the purpose to improve the epitaxy technology.

The purpose of this paper consists in the study of the parameters of  $P-I$  characteristics measured in different areas of the emission spectrum, several types of LED based on InGaN/GaN heterostructures with multiple quantum wells and in detection of the relation between these parameters and the concentration and heterogeneity of indium (In) distribution in quantum wells.

### Experimental procedure

Measurements were carried out in a hardware and software complex for measurement of  $P-I$  characteristics and boundary frequencies of electroluminescence of spectral

components of the LED emission [14]. DC supply to the LED was carried out from a laboratory source of power supply AKIP-1113. The current was controlled by precision multimeter Tektronix DMM4040. Ten values of the current are specified for every decade. Spectrometer Ocean Optics USB2000+VIS+NIR included in the hardware-software complex recorded the emission spectra of LED  $E(\lambda_i)$  at currents  $I$  in the range from 30 nA to 100 mA. The time of exposure of the optical signal was specified in the range of 1 ms–5 s. The spectral resolution of the spectrometer is determined by the value of full width at the level of half power —  $FWHM$ . In the configuration of spectrometer OceanOptics USB2000+ used in the hardware and software complex,  $FWHM = 1.5$  nm. The emission spectra were saved into text files. The spectrum areas to calculate the  $P-I$  characteristics were identified programmatically. The processing of the emission spectra was carried out in MathCAD environment.

For each value of the emission wavelength  $\lambda_i$  the dependence of the emission intensity on the current  $E_i(I)$  was built. The emission intensity  $E$  recorded by the spectrometer is directly proportionate to the emission power of the LED  $P$ . Accordingly, you may transfer to  $P-I$  characteristics  $P_i(I)$  measured in different areas of LED emission spectrum with the spectral resolution of 1.5 nm:

$$P_i(I) = kE_i(I). \quad (1)$$

To approximate the  $P-I$  characteristic of the LED in the range of low currents, at which the effect of Auger recombination can be neglected, in paper [12] a function was proposed based on the ABC model of charge carrier recombination in the heterostructure with the following type

$$P(I) = \frac{m}{2} \left( \sqrt{1 + 2q(I - I_{th})} - 1 \right)^2, \quad (2)$$

where  $I_{th}$  — threshold current, at which the emission of the structure arises,  $m$  and  $q$  — coefficients related to recombination parameters of the light-emitting structure.

It is shown in paper [15] that the coefficient  $q$ , which determines the degree of nonlinearity of the  $P-I$  characteristic, is directly proportional to the radiative recombination coefficient  $B$  and inversely proportional to the square of the coefficient  $A$  of non-radiative recombination:

$$q = \frac{\eta_{inj}}{eV} \frac{2B}{A^2}, \quad (3)$$

where  $\eta_{inj}$  — the coefficient of charge carriers injection into the active region,  $e$  — elementary charge,  $V$  — the volume of the active region of the heterostructure.

In paper [16] it is shown that the nonradiative recombination coefficient  $A$  is proportional to the concentration of the charge carrier capture centers (defects):  $A \sim N_T$ . In paper [13] it was found that the parameter  $q$  and concentration of defects  $N_T$  are related by the dependence of type

$$N_T \sim q^{-0.5}. \quad (4)$$

When approximating the results of measurements of  $P-I$  characteristics of the LED measured with the spectral resolution by function (2) we obtain the function of type

$$P_i(I) = \frac{m_i}{2} \left( \sqrt{1 + 2q_i(I - I_{th,i})} - 1 \right)^2, \quad (5)$$

parameters  $m_i$ ,  $q_i$  and  $I_{th,i}$  of which are defined in the narrow spectral range with width of 1.5 nm with the central wavelength  $\lambda_i$ .

At low currents the parameter  $q$  of the approximating function is related to the internal quantum efficiency (the parameter that defines the efficiency of electric current conversion into optical emission and characterizes the quality of epitaxial layers) by expression [11]

$$\eta_{IQE}(I) = \frac{\sqrt{1 + 2qI} - 1}{\sqrt{1 + 2qI} + 1}. \quad (6)$$

Having measured the emission power of LED  $P(I_1)$  and  $P(I_2)$  at two current values  $I_1$  and  $I_2$  from the range of low currents and having recorded the expression (5) for these values, we obtain the system of equations to find the value of the parameter  $q$ . Substituting the obtained expression for the parameter  $q$  into (6), we obtain the formula for the calculation of IQE at each current value:

$$\eta_{IQE}(I) = \frac{I_1\sqrt{P(I_2)} - I_2\sqrt{P(I_1)}}{P(I_1)\sqrt{P(I_2)} - P(I_2)\sqrt{P(I_1)}} \frac{P(I)}{I}. \quad (7)$$

To calculate the IQE, the current  $I_2$  is specified as equal to  $I_2 = 0.2I_{max}$ , where  $I_{max}$  — current, at which the function  $U(I)/I$  reaches the maximum value, and current  $I_1$  is selected from the condition  $I_1 \approx 0.5I_2 = 0.1I_{max}$ . For the modern LED based on InGaN/GaN-heterostructures the maximum of IQE is reached at current densities 1–10 A/cm<sup>2</sup>.

Substituting to the expression (7) the  $P-I$  characteristic  $P_i(I)$  measured in different areas of the emission spectrum, we obtain the expression for IQE in the  $i$ -th spectral range:

$$\eta_{IQE,i}(I) = \frac{I_1\sqrt{P_i(I_2)} - I_2\sqrt{P_i(I_1)}}{P_i(I_1)\sqrt{P_i(I_2)} - P_i(I_2)\sqrt{P_i(I_1)}} \frac{P_i(I)}{I}. \quad (8)$$

For each emission wavelength  $\lambda_i$  the current  $I_{max,i}$  was defined, at which the spectral quantum efficiency  $\eta_{IQE,i}$  measured with the spectral resolution reaches the maximum value.

In this paper, we studied the dependences of the threshold current  $I_{th,i}$ , parameter of the approximating function  $q_i$  and current  $I_{max,i}$ , when the IQE maximum is reached, on the emission wavelength  $\lambda_i$ , in the vicinity of which the  $P-I$  characteristic of the LED is measured.

## Experimental results and discussion

The LED of three types were investigated: ultraviolet LED of VLMU1610-365-135 type by Vishay Intertechnology Inc., blue LED of ARL-5213PBC type by Arlight and

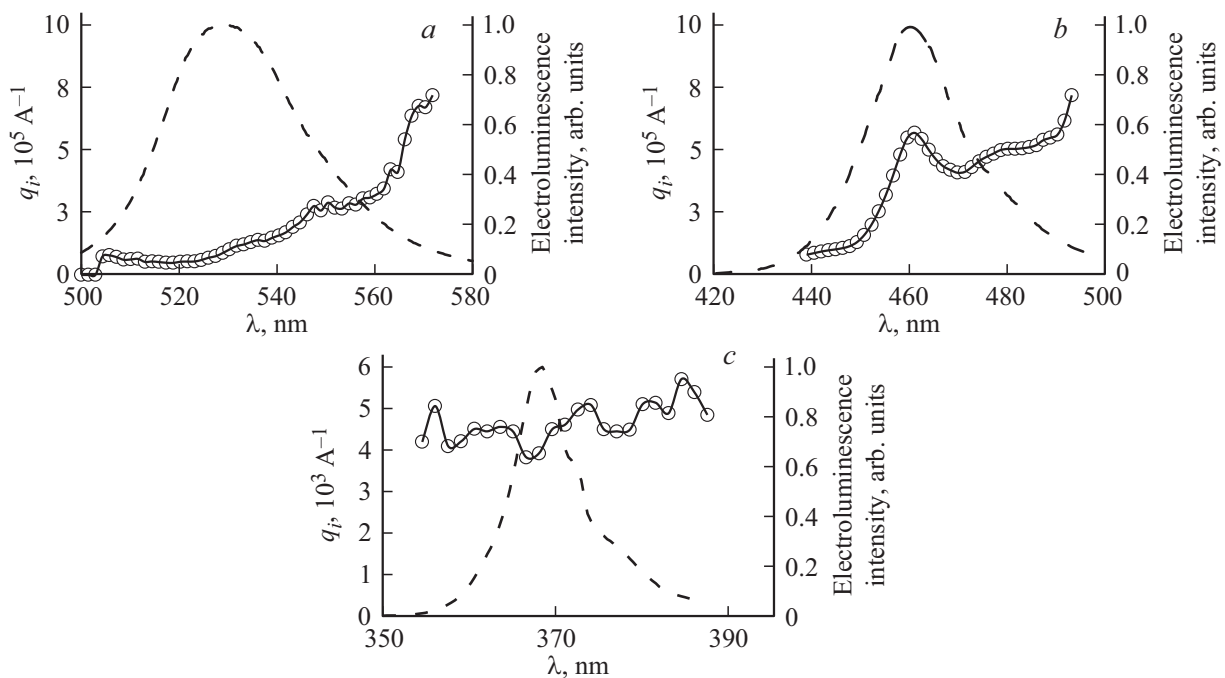

**Figure 1.** Dependence of the parameter  $q_i$  of the approximating function (5) on the wavelength of the emission spectrum of green (a), blue (b) and ultraviolet (c) LED. Dashed lines specify the emission spectra of LED.

green LED ARL-5213PGC by Arlight. All LED have InGaN/GaN heterostructure.

Fig. 1 shows the dependences of the  $q$  parameter on the wavelength of the emission spectrum. From the figure you can see that for the blue LED the parameter  $q$  is 5–10 times higher than for the green ones, and 100 times higher than for the ultraviolet ones. It means that the blue LED have a more linear  $P-I$  characteristic compared to the green and ultraviolet ones.

It was found that for the green LED the parameter  $q_i$  of the approximating function (5) in the short-wavelength range of the emission spectrum is 10 times lower than in the long-wavelength range of the spectrum (Fig. 1, a), for the blue LED — 5 times lower (Fig. 1, b), and for the ultraviolet LED the value of parameter  $q_i$  hardly depends on the emission wavelength (Fig. 1, c).

Analysis of current dependences, at which the maximum of  $P-I$  characteristics is reached, which are measured at different parts of the emission spectrum, from the wavelength of emission, demonstrated that in ultraviolet LED the current  $I_{\max}$  is the same in all wavelengths of the radiation spectrum and is 20 mA (Fig. 2, a). In blue LED the current  $I_{\max}$  in the short-wavelength wing of the spectrum is higher than in the long-wavelength one, and in the long-wavelength wing the current  $I_{\max}$  takes the constant value equal to 100 mA (Fig. 2, b). In green LED in the short-wavelength wing the current  $I_{\max}$  reaches 20 mA, and in the short-wavelength one it drops down to 10 mA (Fig. 2, c).

Dependence  $I_{\max}(\lambda)$  is most pronounced in green LED: in the wavelength range from 500 to 550 nm  $I_{\max, j}$  changes

1000 times. In blue LED the dependence  $I_{\max, j}(\lambda)$  is weaker: in the wavelength range from 440 to 480 nm  $I_{\max, j}$  changes 50 times. In ultraviolet LED the dependence  $I_{\max, j}(\lambda)$  does not show.

The results of measurements of the threshold currents of individual spectral components in the emission of the studied LED are given in Fig. 3. For all studied LED the threshold current of long-wavelength components of the spectrum is higher than the threshold current of short-wavelength components. The relative difference of the threshold current values of spectral components in short-wavelength and long-wavelength wing of the emission spectrum is around 4% for the ultraviolet LED, around 7% for the blue ones, and 30% for the green ones.

To explain the obtained results, let us consider the model of formation of the spectrum of emission by InGaN/GaN-heterostructure with heterogeneous distribution of indium presented in paper [17]. According to the model, the LED may be presented by a combination of parallel joined microdiodes, having the identical parameters of wide-band  $n$ -GaN- and  $p$ -GaN-emitters, but differing from each other by concentration of indium  $x$  in quantum wells (Fig. 4). As a result the short-wavelength wing of the LED emission spectrum is formed by local areas with lower concentration of indium, and the long-wavelength one — with higher one.

In series with this combination of microdiodes the total resistances of  $p$ - and  $n$ -contacts  $R_p$  and  $R_n$  respectively are connected. The surface areas of microdiodes (sectors, sites)  $S(x)$  with different content of indium  $x$  in quantum wells in the first approximation may be described by Gaussian

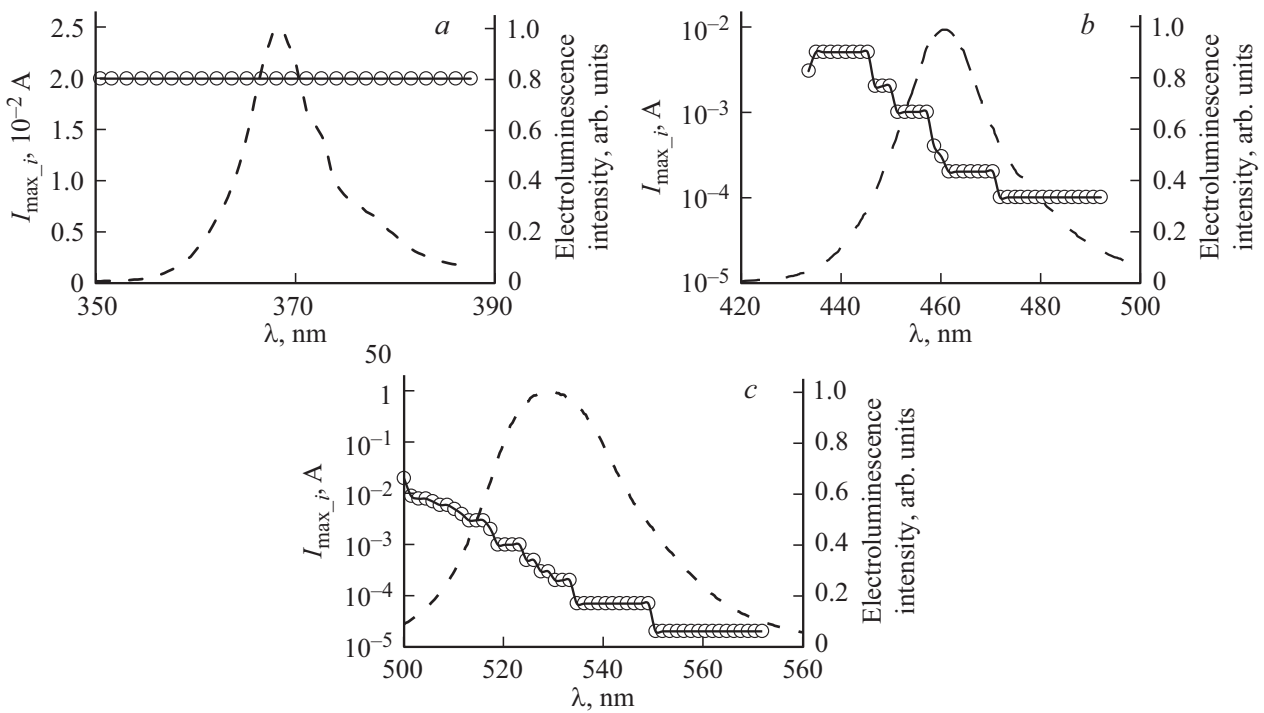

**Figure 2.** Current dependence, at which the maximum IQE is reached, being measured in different parts of the spectrum, on the wavelength of the ultraviolet (a), blue (b) and green (c) LED. Dashed lines specify the emission spectra of LED.

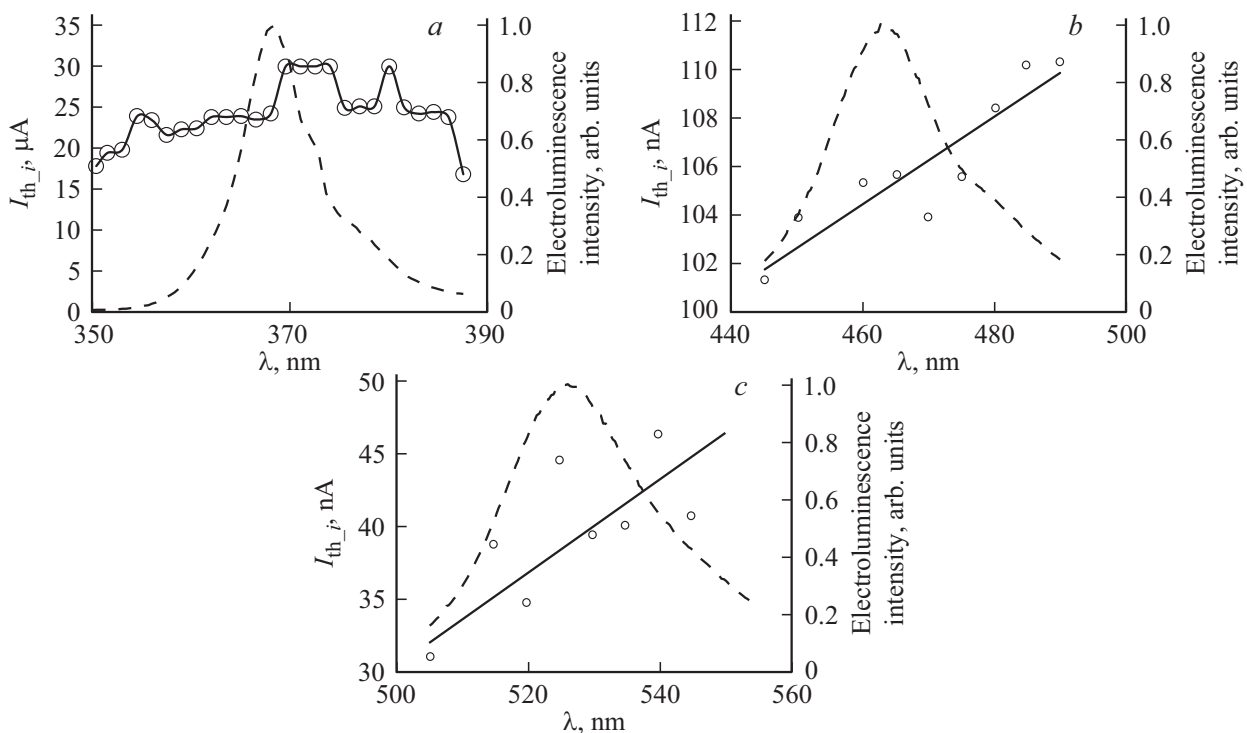

**Figure 3.** Dependence of the threshold current on the wavelength of the emission spectrum of ultraviolet (a), blue (b) and green (c) LED. Dashed lines specify the emission spectra of LED.

distribution relatively to the average values  $x = 0.28$  for green LED,  $x = 0.18$  for blue and  $x = 0.02$  for ultraviolet ones.

Each microdiode has threshold voltage  $U_{th, i}$  ( $i = 1, \dots, k$ ), which is directly proportionate to the width of the band gap and is inversely proportionate to

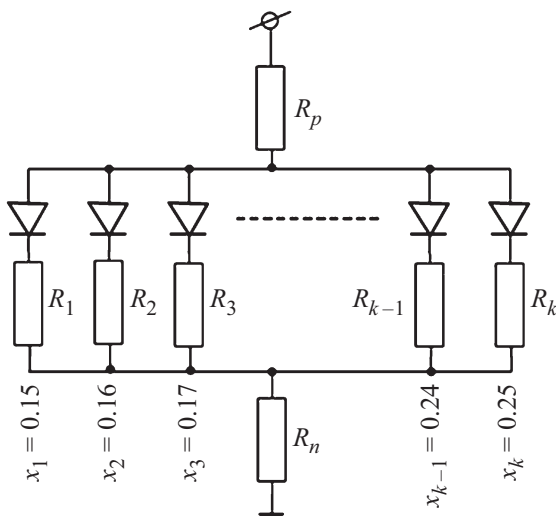

**Figure 4.** Electric model of a LED with heterogeneous distribution of indium in a quantum well of InGaN/GaN-heterostructure of a blue LED [17].

the concentration of indium  $x$  in quantum wells. Since the difference between  $U_{th,1}$  and  $U_{th,k}$  is several percent, the difference in the threshold values of current  $I_{th,1}$  and  $I_{th,k}$  is due to the difference in the serial (differential) resistances of microdiodes  $R_i$  ( $R_1 < R_k$ ), which matches with the results of modelling of volt-ampere characteristics of blue LED with various concentration of indium presented in [17].

Increase of  $x$  indium concentration in the quantum well causes not only formation of clusters, but also increases the extent of the heterogeneity of its distribution [18]. The results of the studies presented in paper [19] show that at indium concentrations exceeding  $x = 0.1$  there is substantial increase in the heterogeneity of its distribution.

The produced experimental results may be interpreted as follows: as the current passes through the heterostructure, the radiative recombination first occurs in the areas with lower concentration of indium, which form the short-wavelength wing of the emission spectrum. As the current increases, emission occurs in the areas of high indium concentration. In the local areas with low indium concentration the maximum of the internal quantum efficiency is reached at high currents, and  $P-I$  characteristic has a high degree of nonlinearity compared to the local areas with high indium concentration. The higher is the heterogeneity of indium concentration in the quantum well, the higher is the relative difference in the values  $I_{th,j}$ ,  $I_{max,j}$  and  $q_i$  in long-wavelength and short-wavelength components of the spectrum.

## Conclusion

The paper presents the results of investigations of the  $P-I$  characteristic parameters of ultraviolet, blue and green LED based on InGaN/GaN-heterostructures with multiple

quantum wells measured in different parts of the emission spectrum with spectral resolution of 1.5 nm. It was found that in LED of all studied types the threshold current of long-wavelength components of the spectrum is higher than the threshold current of short-wavelength components, besides, for green LED this difference is more substantial than for the ultraviolet and blue LED. The parameter of the approximating function  $q$  that determines the degree of nonlinearity of the  $P-I$  characteristic in the low current range, in green LED in the short-wavelength range of the emission spectrum is 10 times lower than in the long-wavelength range of the spectrum, for the blue LED — 5 times, and for the ultraviolet LED it hardly depends on the emission wavelength. Based on the model presenting a LED with heterogeneous distribution of indium concentration in the quantum wells in the form of multiple parallel connected microdiodes with different width of the band gap, it is shown that the differences in the values of  $P-I$  characteristics measured with the spectral resolution, in the short-wavelength and long-wavelength parts of the emission spectrum in InGaN/GaN heterostructures are determined by concentration and heterogeneous distribution of indium in the quantum well. The relative difference of the values of  $P-I$  characteristic parameters measured with the spectral resolution may be used for indirect estimation of the degree of heterogeneity of indium concentration distribution in the InGaN/GaN-quantum well.

## Funding

This work was supported by the Ministry of Science and Higher Education of the Russian Federation under the state assignment of the V.A. Kotelnikov Institute of Radio Engineering and Electronics of the Russian Academy of Sciences (FFWZ-2025-0001).

## Conflict of interest

The authors declare that they have no conflict of interest.

## References

- [1] A.R. Rasul, K.N. Orlova. Vestnik Natsionalnogo issledovatel'skogo yadernogo universiteta „MIFI“, **13** (1), 52 (2024) (in Russian). DOI: 10.26583/vestnik.2024.308
- [2] M. Meneghini, N. Trivellin, G. Meneghesso, E. Zanoni, U. Zehnder, B. Hahn. J. Appl. Phys., **106**, 114508 (2009). DOI: 10.1063/1.3266014
- [3] D.S. Meyaard, G.-B. Lin, J. Cho, E.F. Schubert. *Nitride Semiconductor Light-Emitting Diodes (LEDs): Materials, Technologies and Applications* (Woodhead Publishing, 2014), p. 279–300. DOI: 10.1533/9780857099303.2.279
- [4] M.A. Mintairov, V.V. Evstropov, N.A. Kalyuzhny, D.A. Malevsky, S.A. Mintairov, M.Z. Shvarts. Opt. i spektr., **132** (12), 1214 (2024) (in Russian). DOI: 10.61011/OS.2024.12.59794.6601-24
- [5] A.V. Gradoboev, K.N. Orlova, F.F. Zhamaldinov. Pribory i tekhnika eksperimenta, **1**, 80 (2023) (in Russian).

- DOI: 10.56304/S2304487X21060080
- [6] N. Renso, C. De Santi, A. Caria, F. Dalla Torre, L. Zecchin, G. Meneghesso, E. Zanoni, M. Meneghini. *J. Appl. Phys.*, **127**, 185701 (2020). DOI: 10.1063/1.5135633
- [7] C. Li, Z. Ji, J. Li, M. Xu, H. Xiao, X. Xu. *Sci. Rep.*, **7**, 15301 (2017). DOI: 10.1038/s41598-017-15561-9
- [8] A.M. Ivanov, A.V. Klochkov. *Opt. i spektr.*, **133** (4), 390 (2025) (in Russian). DOI: 10.61011/OS.2025.04.60535.7296-24
- [9] A.V. Klyuev, A.V. Yakimov. *Physica B: Condensed Matter*, **440**, 145 (2014). DOI: 10.1016/j.physb.2014.01.021
- [10] A.V. Klyuev. *Nanomaterialy i nanostruktury-XXI vek*, **5** (1), 42 (2014) (in Russian).
- [11] I. Frolov, V. Sergeev, O. Radaev. *Poluprovodnikovaya svetotekhnika*, **1**, 12 (2023) (in Russian).
- [12] O.A. Radaev, I.V. Frolov, V.A. Sergeev, S.A. Zaytsev. *Kontrol. Diagnostika*, **28** (7), 61 (2025) (in Russian). DOI: 10.14489/td.2025.07.pp.061-066
- [13] I.V. Frolov. *Radioelektronika. Nanosistemy. Informatsionnyie tekhnologii*, **16** (4), 441 (2024) (in Russian). DOI: 10.17725/rensit.2024.16.441
- [14] O.A. Radaev, V.A. Sergeev, I.V. Frolov. *Izmeritel'naya tekhnika*, **8**, 42 (2019) (in Russian). DOI: 10.32446/0368-1025it.2019-8-42-46
- [15] V.A. Sergeev, O.A. Radaev, I.V. Frolov. *Pribory i tekhnika eksperimenta*, **6**, 103 (2023) (in Russian). DOI: 10.31857/S0032816223060071
- [16] L.W. Xu, K.Y. Qian. *IEEE Photonics J.*, **9** (4), 8201309 (2017). DOI: 10.1109/JPHOT.2017.2703851
- [17] S.G. Nikiforov. *Razrabotka sredstv izmereniy i metodov kontrolya parametrov poluprovodnikovyykh izluchateley na osnove soedineniy  $A^{III}B^V$ , ispolzuemykh v vysokonadezhnykh priborakh*. Dokt. dis. (Moskovsky institut elektronnoy tekhniki, M., 2015) (in Russian).
- [18] A. Di Vito, A. Pecchia, A. Di Carlo, M. Auf der Maur. *Japan. J. Appl. Phys.*, **58**, SCCC03 (2019). DOI: 10.7567/1347-4065/ab06ba
- [19] R. Butté, L. Lahourcade, T.K. Uzdavinys, G. Callsen, M. Mensi, M. Glauser, G. Rossbach, D. Martin, J.-F. Carlin, S. Marcinkevičius, N. Grandjean. *Appl. Phys. Lett.*, **112** (3), 032106 (2018). DOI: 10.1063/1.5010879

*Translated by M.Verenikina*